



ES50/50 / ES50/50TE Service Manual

American Dryer Corporation
88 Currant Road
Fall River MA 02720-4781 USA
Telephone: +1 (508) 678-9000 / Fax: +1 (508) 678-9447
E-mail: techsupport@amdry.com / parts@amdry.com

www.amdry.com

Retain This Manual in a Safe Place for Future Reference

This product embodies advanced concepts in engineering, design, and safety. If this product is properly maintained, it will provide many years of safe, efficient, and trouble free operation.

Only qualified technicians should service this equipment.

OBSERVE ALL SAFETY PRECAUTIONS displayed on the equipment or specified in the installation manual included with the dryer.

The following "FOR YOUR SAFETY" caution must be posted near the dryer in a prominent location.

FOR YOUR SAFETY

Do not store or use gasoline or other flammable vapors and liquids in the vicinity of this or any other appliance.

POUR VOTRE SÉCURITÉ

Ne pas entreposer ni utiliser d'essence ni d'autres vapeurs ou liquides inflammables à proximité de cet appareil ou de tout autre appareil.

We have tried to make this manual as complete as possible and hope you will find it useful. The manufacturer reserves the right to make changes from time to time, without notice or obligation, in prices, specifications, colors, and material, and to change or discontinue models. The illustrations included in this manual may not depict your particular dryer exactly.

IMPORTANT

For your convenience, log the following information:

DATE OF PURCHASE _____ MODEL NO. _____

RESELLER'S NAME _____

SERIAL NUMBER(S) _____

Replacement parts can be obtained from your reseller or the ADC factory. When ordering replacement parts from the factory, you can FAX your order to ADC at +1 (508) 678-9447 or telephone your order directly to the ADC Parts Department at +1 (508) 678-9000 or contact parts@amdry.com. Please specify the dryer model number and serial number in addition to the description and part number, so that your order is processed accurately and promptly.

"IMPORTANT NOTE TO PURCHASER"

Information must be obtained from your local gas supplier on the instructions to be followed if the user smells gas. These instructions must be posted in a prominent location near the dryer.

IMPORTANT

You must disconnect and lockout the electric supply and the gas supply or the steam supply before any covers or guards are removed from the machine to allow access for cleaning, adjusting, installation, or testing of any equipment per OSHA standards.

Please observe all safety precautions displayed on the equipment and specified in the installation manual included with the dryer.

FOR YOUR SAFETY

Do not store or use gasoline or other flammable vapors and liquids in the vicinity of this or any other appliance.

Do not dry mop heads in the dryer.

Do not use dryer in the presence of dry cleaning fumes.

CAUTION

Dryers should never be left unattended while in operation.

“Caution: Label all wires prior to disconnection when servicing controls. Wiring errors can cause improper operation.”

«Attention: Au moment de l'entretien des commandes, étiquetez tous les fils avant de les débrancher. Des erreurs de câblage peuvent entraîner un fonctionnement inadéquat et dangereux.»

WARNING

Children should not be allowed to play on or near the dryers.

Children should be supervised if near dryer(s) in operation.

The dryer must never be operated with any of the back guards, outer tops, or service panels removed. Personal injury or fire could result.

The dryer must never be operated without the lint filter or screen in place, even if an external lint collection system is used.

The wiring diagram for the dryer is located in the front electrical control box area.

Table of Contents

| | |
|--------------------------------------------------------|----|
| Important Information | 4 |
| A. Safety Precautions | 4 |
| Routine Maintenance | 6 |
| A. Cleaning | 6 |
| B. Adjustments | 7 |
| Installation Requirements | 8 |
| A. Enclosure, Air Supply, and Exhaust Requirements ... | 8 |
| B. Electrical and Gas Requirements | 8 |
| C. Operational Service Check Procedure | 9 |
| Description of Parts | 10 |
| A. Control Panel (Microprocessor) | 10 |
| B. Global | 10 |
| C. Gas Burner Assembly | 10 |
| D. Drive Motor | 11 |
| E. Impellor (Blower Motor) | 11 |
| F. Tumbler | 11 |
| G. Main Door Switch | 12 |
| H. Sail Switch | 12 |
| I. Burner Thermostat | 12 |
| J. Exhaust Hi-Limit Thermostat | 13 |
| K. Lint Drawer | 13 |
| L. Lint Drawer Switch | 13 |
| M. Relay Panel Assembly | 13 |
| Servicing | 14 |
| Introduction | 14 |
| A. Computer Controls | 14 |
| B. Glo-Bar Controls | 16 |
| C. Thermostats | 19 |
| D. Sail Switch Assembly | 19 |
| E. Front Panel and Main Door Assemblies | 20 |
| F. To Replace Lint Drawer Switch | 24 |
| Faults | 28 |
| Events | 29 |
| Technical Information | 30 |
| A. Data Label | 30 |
| B. Using A Manometer | 31 |

List of Acronyms

| | |
|----------|-----------------------------------------------|
| L.P. | Liquid Propane |
| OSHA | Occupational Safety and Health Administration |
| T.E.F.C. | Totally Enclosed, Fan-Cooled |

SECTION I

IMPORTANT INFORMATION

A. SAFETY PRECAUTIONS

WARNING: For your safety, the information in this manual must be followed to minimize the risk of fire or explosion or to prevent property damage, personal injury, or loss of life.

The dryer must never be operated with any of the back guards, outer tops, or service panels removed. PERSONAL INJURY OR FIRE COULD RESULT.

1. Do not store or use gasoline or other flammable vapors and liquids in the vicinity of this or any other appliance.
2. Purchaser/user should consult the local gas supplier for proper instructions to be followed in the event the user smells gas. The instructions should be posted in a prominent location.
3. WHAT TO DO IF YOU SMELL GAS...
 - a. Do not try to light any appliance.
 - b. Do not touch any electrical switch.
 - c. Do not use any phone in your building.
 - d. Clear the room, building, or area of all occupants.
 - e. Immediately call your gas supplier from a neighbor's phone. Follow the gas supplier's instructions.
 - f. If you cannot reach your gas supplier, call the fire department.
4. Installation and service must be performed by a qualified installer, service agency, or gas supplier.
5. Dryer(s) must be exhausted to the outdoors.
6. Although ADC produces a very versatile dryer, there are some articles that, due to fabric composition or cleaning method, should not be dried in it.

WARNING: Dry only water washed fabrics. Do not dry articles spotted or washed in dry cleaning solvents, a combustible detergent, or "all purpose" cleaner. EXPLOSION COULD RESULT.

Do not dry rags or articles coated or contaminated with gasoline, kerosene, oil, paint, or wax. EXPLOSION COULD RESULT.

Do not dry mop heads. Contamination by wax or flammable solvents will create a fire hazard.

Do not use heat for drying articles that contain plastic, foam, sponge rubber, or similarly textured rubber materials. Drying in a heated tumbler may damage plastics or rubber and may be a fire hazard.

7. A program should be established for the inspection and cleaning of lint in the heating unit area, exhaust ductwork, and inside the dryer. The frequency of inspection and cleaning can best be determined from experience at each location.

WARNING: The collection of lint in the burner area and exhaust ductwork can create a potential fire hazard.

8. For personal safety, the dryer must be electrically grounded in accordance with local codes and/or the National Electrical Code ANSI/NFPA NO. 70-LATEST EDITION or in Canada, the Canadian Electrical Codes Parts 1 & 2 CSA C22.1-1990 or LATEST EDITION.

NOTE: Failure to do so will void the warranty.

9. Under no circumstances should the dryer door switches, lint door switch, heat safety circuit ever be disabled.

WARNING: PERSONAL INJURY OR FIRE COULD RESULT.

10. This dryer is not to be used in the presence of dry cleaning solvents or fumes.

11. Remove articles from the dryer as soon as the drying cycle has been completed.

WARNING: Articles left in the dryer after the drying and cooling cycles have been completed can create a fire hazard.

12. Do not operate steam dryers with more than 150 PSI (10.34 bars) steam pressure. Excessive steam pressure can damage steam coil and/or harm personnel.

13. Replace leaking flexible hoses or other steam fixtures immediately. Do not operate the dryer with leaking flexible hoses. PERSONAL INJURY MAY RESULT.

14. **READ AND FOLLOW ALL CAUTION AND DIRECTION LABELS ATTACHED TO THE DRYER.**

WARNING: YOU MUST DISCONNECT AND LOCKOUT THE ELECTRIC SUPPLY AND THE GAS SUPPLY OR THE STEAM SUPPLY BEFORE ANY COVERS OR GUARDS ARE REMOVED FROM THE MACHINE TO ALLOW ACCESS FOR CLEANING, ADJUSTING, INSTALLATION, OR TESTING OF ANY EQUIPMENT PER OSHA STANDARDS.

SECTION II

ROUTINE MAINTENANCE

A. CLEANING

A program or schedule should be established for periodic inspection, cleaning, and removal of lint from various areas of the dryer, as well as throughout the ductwork system. The frequency of cleaning can best be determined from experience at each location. Maximum operating efficiency is dependent upon proper air circulation. The accumulation of lint can restrict this airflow. If the guidelines in this section are met, an ADC dryer will provide many years of efficient, trouble free, and most importantly, safe operation.

WARNING: LINT FROM MOST FABRICS IS HIGHLY COMBUSTIBLE. THE ACCUMULATION OF LINT CAN CREATE A POTENTIAL FIRE HAZARD.

KEEP DRYER AREA CLEAR AND FREE FROM COMBUSTIBLE MATERIALS, GASOLINE, AND OTHER FLAMMABLE VAPORS AND LIQUIDS.

NOTE: Suggested time intervals shown are for average usage which is considered six to eight operational (running) hours per day.

Clean lint drawer and screen every third or fourth load.

NOTE: Frequency can best be determined at each location.

DAILY

Beginning of each work shift.

Clean lint from the drawer and screen. Inspect lint screen and replace if torn.

WEEKLY

Clean lint accumulation from lint chamber, thermostat, and microprocessor temperature sensor area.

WARNING: To avoid the hazard of electrical shock, discontinue electrical supply to the dryer.

STEAM DRYERS

Clean steam coil fins using compressed air and a vacuum cleaner with brush attachment.

NOTE: When cleaning steam coil fins, be careful not to bend the fins. If the fins are bent, straighten by using a fin comb, which is available from local air conditioning supply houses.

90 DAYS

Remove lint from tumbler, drive motors, and surrounding areas. Remove lint from gas valve burner area with a dusting brush or vacuum cleaner attachment.

NOTE: To prevent damage, avoid cleaning and/or touching the ignitor/globar probe assembly.

6 MONTHS

Inspect and remove lint accumulation in customer furnished exhaust ductwork system and from dryer's internal exhaust ducting.

NOTE: THE ACCUMULATION OF LINT IN THE EXHAUST DUCTWORK CAN CREATE A POTENTIAL FIRE HAZARD.

DO NOT OBSTRUCT THE FLOW OF COMBUSTION AND VENTILATION AIR. CHECK CUSTOMER FURNISHED BACK DRAFT DAMPERS IN THE EXHAUST DUCTWORK. INSPECT AND REMOVE ANY LINT ACCUMULATION, WHICH CAN CAUSE THE DAMPER TO BIND OR STICK.

A back draft damper that is sticking partially closed can result in slow drying and shutdown of heat circuit safety switches or thermostats.

When cleaning the dryer cabinet(s), avoid using harsh abrasives. A product intended for the cleaning of appliances is recommended.

B. ADJUSTMENTS

7 DAYS AFTER INSTALLATION AND EVERY 6 MONTHS THEREAFTER

Inspect bolts, nuts, screws, grounding connections, and nonpermanent gas connections (unions, shutoff valves, and orifices). Motor and drive belts should be examined. Cracked or seriously frayed belts should be replaced. Complete operational check of controls and valves. Complete operational check of all safety devices (door switches, lint drawer switch, sail switch, burner and hi-limit thermostats).

SECTION III

INSTALLATION REQUIREMENTS

Installation should be performed by competent technicians in accordance with local and state codes. In the absence of these codes, the installation must conform to applicable American National Standards: ANSI Z223.1-LATEST EDITION (National Fuel Gas Code) or ANSI/NFPA NO. 70-LATEST EDITION (National Electrical Code) or in Canada, the installation must conform to applicable Canadian Standards: CAN/CGA-B149.1-M91 (Natural Gas) or CAN/CGA-B149.2-M91 (L.P. Gas) or LATEST EDITION (for General Installation and Gas Plumbing) or Canadian Electrical Codes Parts 1 & 2 CSA C22.1-1990 or LATEST EDITION (for Electrical Connections).

A. ENCLOSURE, AIR SUPPLY, AND EXHAUST REQUIREMENTS

NOTE: The following information is very brief and general. For a detailed description, refer to the Installation Manual supplied with the dryer.

Bulkheads and partitions around the dryer should be made of noncombustible materials. Allowances should be made for the opening and closing of the control door and lint drawer. Also, allowances should be made in the rear for ease of maintenance. (Refer to the appropriate Installation Manual for recommended distances and minimum allowances required.)

When the dryer is operating, it draws in room air, heats it, passes this air through the tumbler, and exhausts it out of the building. Therefore, the room air must be continually replenished from the outdoors. If the make-up air is inadequate, drying time and drying efficiency will be adversely affected. Ignition problems and sail switch "fluttering" problems on gas dryers may result, and you also could have premature motor failure from overheating. The air supply must be given careful consideration to insure proper performance of each dryer.

IMPORTANT: Make-up air must be provided from a source free of dry cleaning fumes. Make-up air that is contaminated by dry cleaning fumes will result in irreparable damage to the motors and other dryer components.

Exhaust ductwork should be designed and installed by a competent technician. Improperly sized ductwork will create excessive back pressure, which will result in slow drying, increased use of energy, and shutdown of the burner by the airflow (sail) switch, burner hi-limit or lint chamber hi-heat protector thermostat. (Refer to the appropriate Installation Manual for more details.)

CAUTION: IMPROPERLY SIZED OR INSTALLED EXHAUST DUCTWORK CAN CREATE A POTENTIAL FIRE HAZARD.

B. ELECTRICAL AND GAS REQUIREMENTS

It is your responsibility to have all electrical connections made by a properly licensed and competent electrician to assure that the electrical installation is adequate and conforms to local and state regulations or codes. In the absence of such codes, all electrical connections, materials, and workmanship must conform to the applicable requirements of the National Electrical Code ANSI/NFPA NO. 70-LATEST EDITION or in Canada, the Canadian Electrical Codes Parts 1 & 2 CSA C22.1-1990 or LATEST EDITION.

IMPORTANT: Failure to comply with these codes or ordinances and/or the requirements stipulated in this manual can result in personal injury or component failure.

The gas dryer installation must meet the American National Standard...National Fuel Gas Code ANSI Z223.1-LATEST EDITION, or in Canada, the Canadian Installation Codes CAN/CGA-B149.1 M91 (Natural Gas) or CAN/CGA-B149.2-M91 (L.P. Gas) or LATEST EDITION, as well as local codes and ordinances and must be done by a qualified professional.

NOTE: Undersized gas piping will result in ignition problems, slow drying, and can create a safety hazard.

The dryer must be connected to the type of gas (natural or L.P.) indicated on the dryer data label. If this information does not agree with the type of gas available, contact the reseller who sold the dryer or contact the factory.

The gas input ratings shown on the dryer data label are for elevations up to 2,000 feet (609.6 meters), unless elevation requirements of over 2,000 feet (609.6 meters) were specified at the time the dryer order was placed with the factory. The adjustment for dryers in the field for elevations over 2,000 feet (609.6 meters) is made by changing the burner orifices. If this adjustment is necessary, contact the reseller who sold the dryer or contact the factory.

NOTE: Any burner changes must be made by a qualified technician.

C. OPERATIONAL SERVICE CHECK PROCEDURE

1. Turn on electric power to the dryer.
2. To start dryer:
 - a. Display will read "Select Cycle."
 - b. Select a cycle using the keypad of the microprocessor controller (computer).
 - c. The dryer will start, and the display will show cycle type and minutes remaining.
3. Make a complete operational check of all the operating controls to assure that the timing is correct, temperature selection switches are functioning, etc.
4. Make a complete operational check of all safety-related circuits: door switch(es), hi-limit thermostat, sail switch, cycling thermostats, etc.
5. For gas dryers a gas pressure test should be taken at the gas valve pressure tap of each dryer to assure that the water column pressure is correct and consistent.

NOTE: Water column pressure requirements (measured at the pressure tap on the gas valve body):

Natural Gas _____ 3.0 Inches (6.9 mb) Water Column.

L.P. Gas _____ 10.5 Inches (26.1 mb) Water Column.

6. If computer program changes are required, refer to the Phase 8 Non-Coin Operator's Manual (ADC P/N 113604) for details.
7. The dryer should be operated through one complete cycle to assure that no further adjustments are necessary and that all components are functioning properly.

SECTION IV

DESCRIPTION OF PARTS

A. CONTROL PANEL (MICROPROCESSOR)

Lifting the control door will reveal the control panel assembly. Opening the control panel will allow access to the major components which include the computer board and keypad. The keypad inputs to the computer what temperature and program has been selected. The computer controls the entire operation of the dryer. It accepts inputs and gives outputs to various parts throughout the dryer.

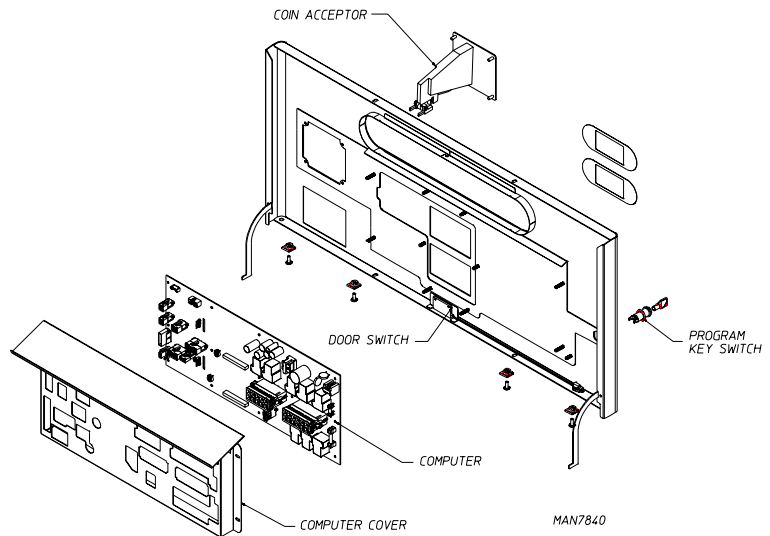

B. GLOBAR

The globar is a 120 VAC device. When the Globar meets its peak radiant heat the I-R sensor "infrared sensor" senses the heat and powers the gas valve.

C. GAS BURNER ASSEMBLY

Gas heated dryers are equipped with a gas burner assembly consisting of two each of a burner tube, gas valve, Glo-Bar and infrared sensor. The inlet piping enters through the rear of the dryer on the right-hand side (viewing from the front) and runs to the front of the dryer where the gas valves are located.

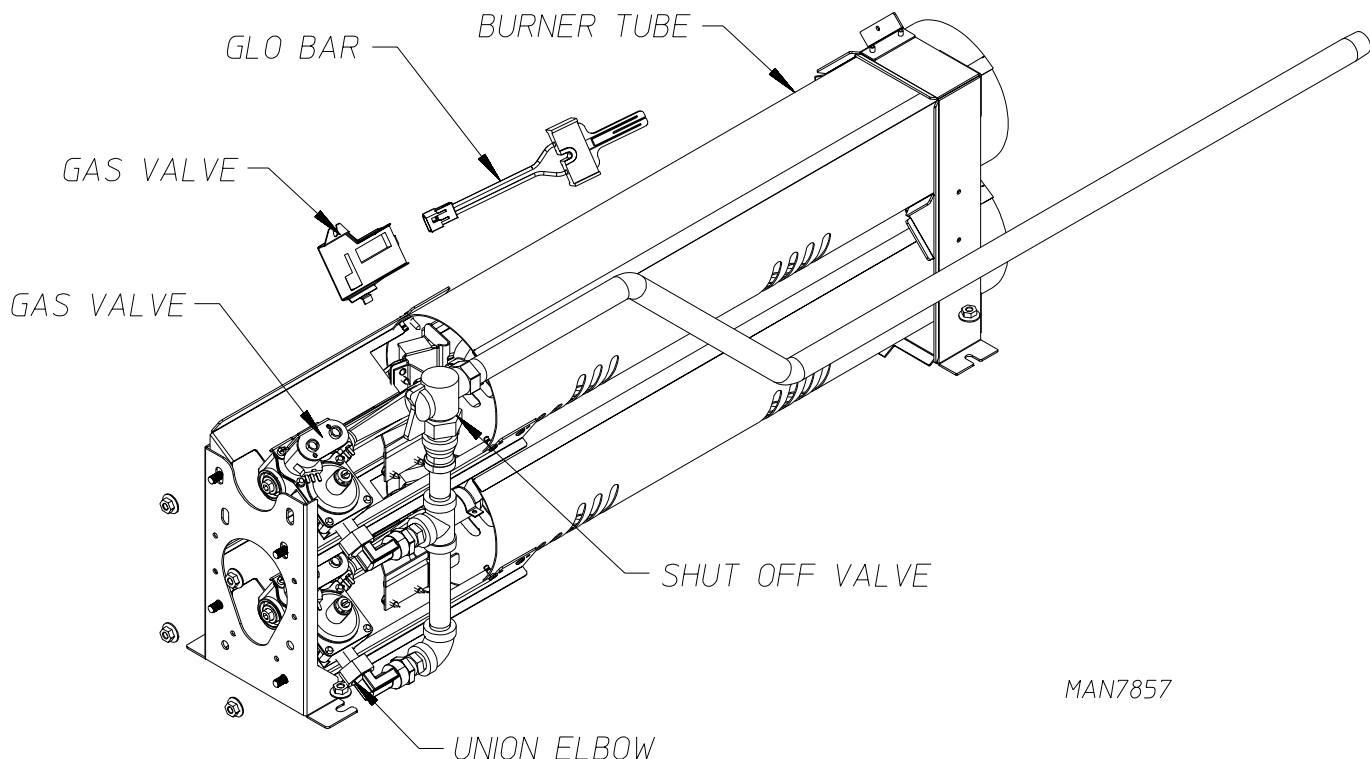

D. DRIVE MOTOR

The drive motor is located in the left side of the machine (viewing from the front) of the dryer. It sits on an adjustable base so that the motor can be easily adjusted for belt tension adjustment. The drive motor is a 1/3 HP motor and operates on 115 to 230 volts, 50/60 Hz.

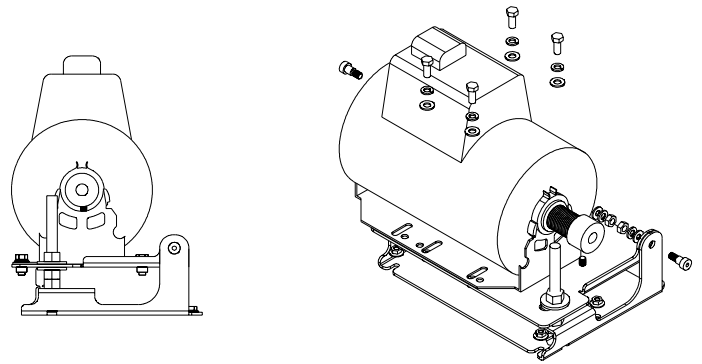

MAN7805

E. IMPELLOR (BLOWER MOTOR)

For ES50/50 (rear exhaust models)

(Viewing from the rear of the dryer.) The blower motor is a motorized impellor, which has a backward curved fan and sits in a sealed box behind the lint screen.

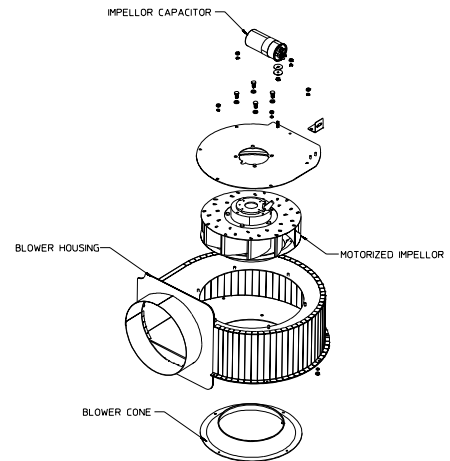

MAN7858

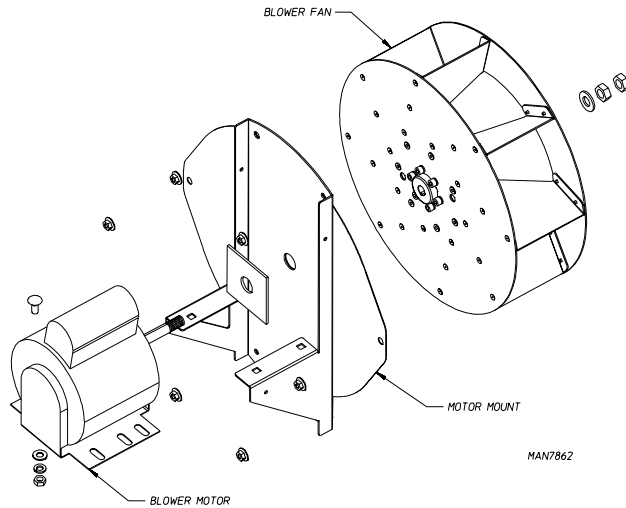

MAN7862

For ES50/50TE (top exhaust)

(Viewing from the rear.) The blower motor assembly consists of a motor, fan, and motor mount. This assembly mounts to the blower housing at the lower back wall of each tumbler.

F. TUMBLER

The tumbler has four ribs, a front felt, and a back felt, which are used to seal the tumbler to the front and rear wall of the dryer.

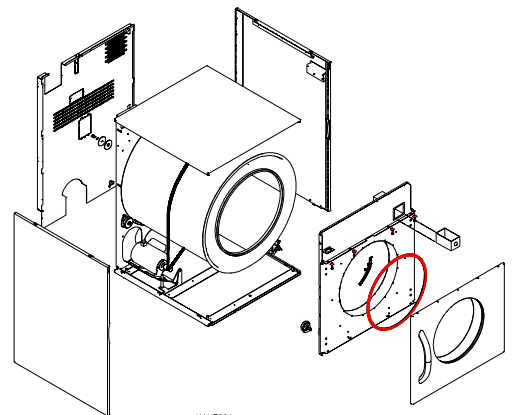

MAN7806

G. MAIN DOOR SWITCH

The main door switch is located in the panel directly above the door. When the main door opens, the switch will also open, preventing the dryer from operating. The main door switch is a safety device and should never be disabled.

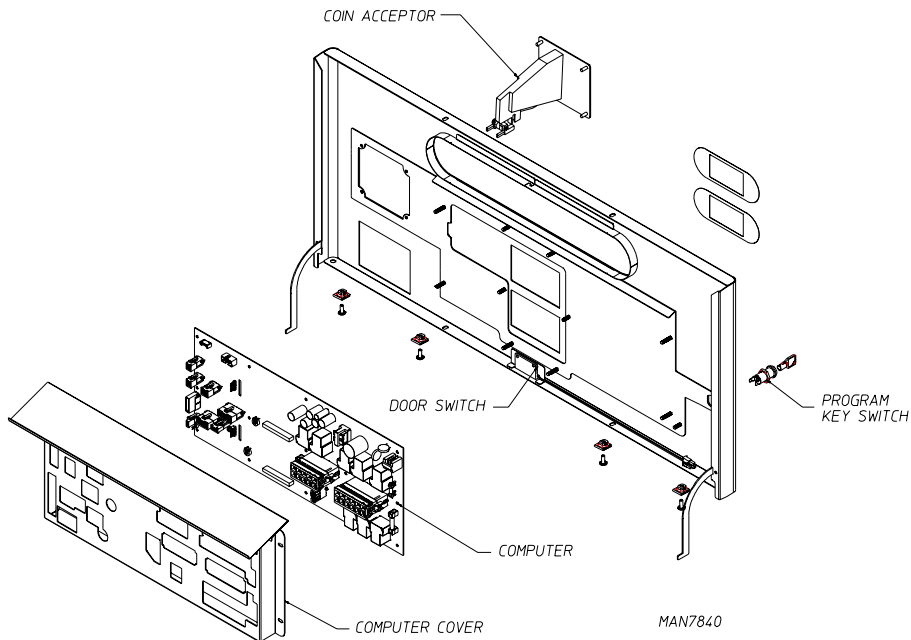

H. SAIL SWITCH

The sail switch is located on the rear of the machine. A sail switch consists of a round damper plate on a lever arm which is in contact with an electric switch. When the blower fan comes on, it draws air through the gas burner. This creates a negative pressure inside the burner box, and this negative pressure pulls in the round damper and activates the sail switch. If there is improper airflow, the damper will not pull in, preventing the burner from starting.

Improper airflow can be caused by improperly designed exhaust ducting where the duct run is too long or has too many sharp bends in it. It can also be caused by faulty seals in the dryer or a lack of make-up air.

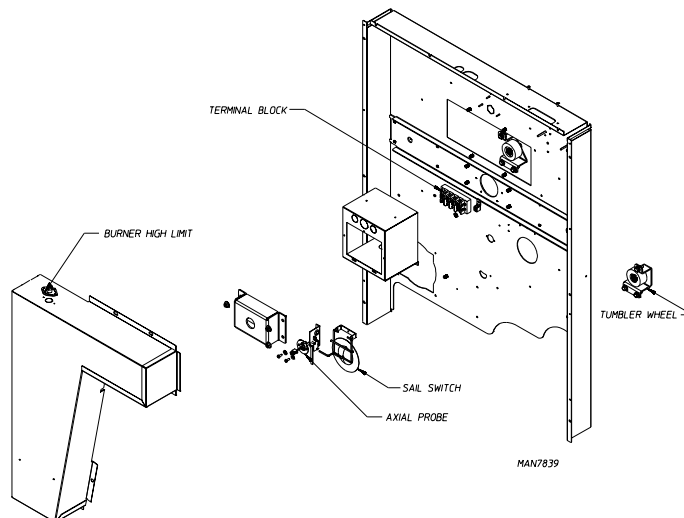

I. BURNER THERMOSTAT

A hi-limit thermostat is located at the top of the heat duct. This is an automatic reset disc-type thermostat set at 205° F (96.11° C). If the flame in the burner should get too hot, this thermostat will shut off the burner. This is generally caused by low airflow through the dryer.

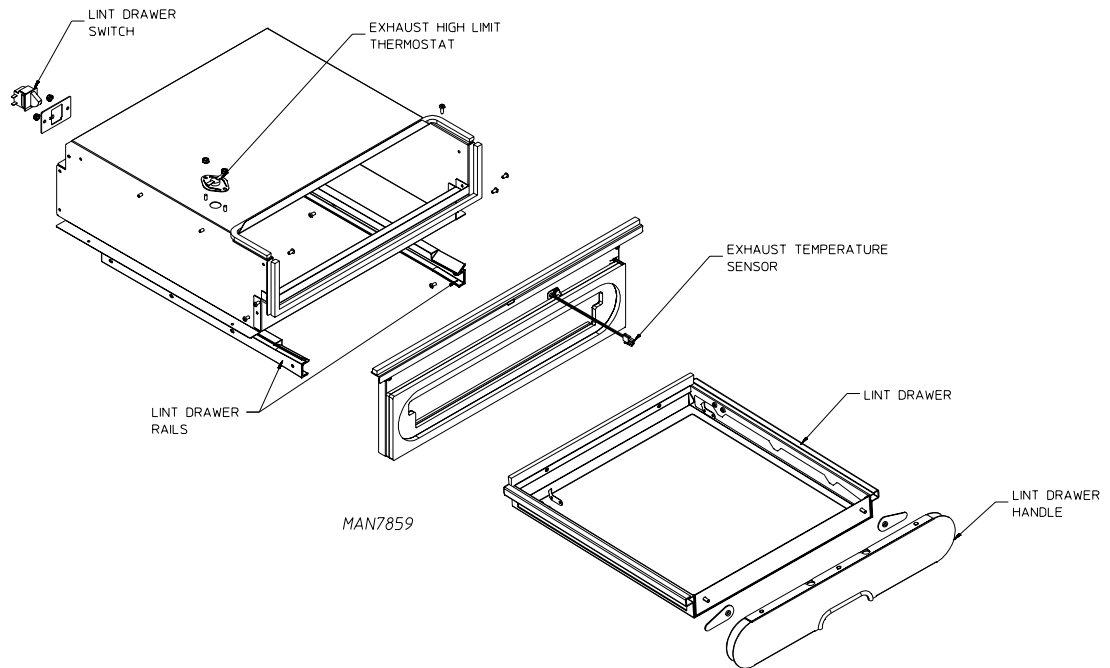

J. EXHAUST HI-LIMIT THERMOSTAT

This is a 190° automatic thermostat located in the lint compartment above the lint drawer. This thermostat senses the heated air after it has passed through the tumbler. If the air temperature gets too hot, the thermostat will shut off the burner. Tumbler and blower will run, but dryer will not heat. The dryer will not heat until the air temperature cools down. At this time, the thermostat will reset.

K. LINT DRAWER

The lint drawer is a pullout type and is located at the bottom of the lint compartment. Simply grab the lint drawer handle, slide out the drawer, brush off the lint, and slide the drawer back in. The lint screen must be kept clean in order for the dryer to operate properly and efficiently.

L. LINT DRAWER SWITCH

The lint drawer switch is located in the rear of the lint compartment. The lint drawer switch insures that the dryer will operate only when the lint drawer is completely closed. This is a safety device and should never be disabled.

M. RELAY PANEL ASSEMBLY

The relay panel is located directly in front of the blower motor (when viewing from the rear). This panel will include the heat relay and possibly a reversing relay and transformer depending on options.

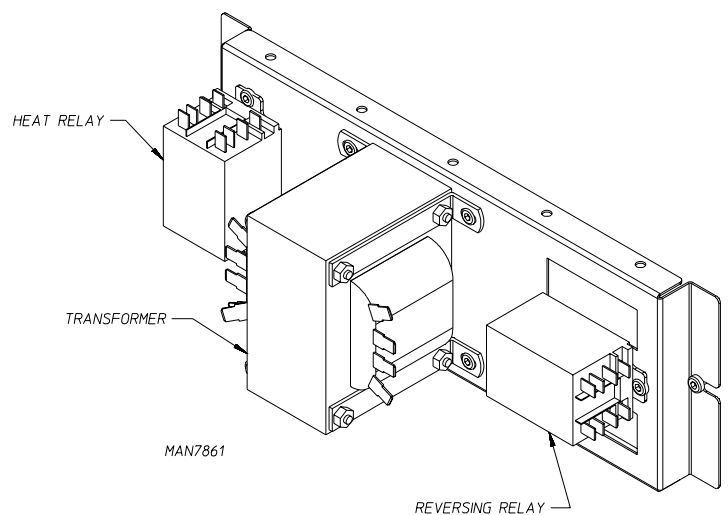

SECTION V

SERVICING

INTRODUCTION

All electrical/mechanical service or repairs should be made with the electrical power to the dryer disconnected (power off).

WARNING: PERSONAL INJURY COULD RESULT.

The information provided in this section should not be misconstrued as a device for use by an untrained person making repairs. Service work should be performed by competent technicians in accordance with local, state, and federal codes.

When contacting the factory for assistance, always have the dryer model and serial numbers available.

CAUTION: Observe all safety precautions displayed on the dryer or specified in this manual before and while making repairs.

Before considering replacement, make sure that all connectors are in place and making proper contact.

A. COMPUTER CONTROLS

To Replace Computer

1. Discontinue electrical power to the dryer.
2. See instructions for “removing control and lint door/toe panel”.
3. Disconnect main power harness from rear of computer by squeezing locking tab and pulling all other connectors from rear of computer board.
4. Disconnect the green ground wire from the computer panel.
5. Disconnect keypad ribbon from the computer.
6. Remove the four hex nuts securing the computer cover to the control panel. Remove the eight Phillips pan head screws, pull back on computer board to remove.
7. Install new computer by reversing this procedure.
8. When replacing the computer, the computer must be programmed. (Please refer to the Computer Operator’s Manual for details.)
9. Reestablish electrical power to the dryer.

Removing Control Door and Lint Door / Toe Panel

1. Discontinue power to unit.
2. Open loading door to find four TORX® screws located at the top of each panel. The control panel will also have screws at the bottom edge, which must be removed.
3. Hinge panel down from the top then lift up to remove. Control panel wiring will need to be removed before panel can be taken off machine.
4. Reinstall panels by reversing this procedure.

To Replace Keypad Label Assembly

1. Discontinue electrical power to the dryer.
2. Repeat step 1-5 for computer board removal.
3. Slowly peel off and remove keypad label assembly from control panel.
4. Peel paper backing off new keypad label assembly.
5. Holding the new keypad label assembly close to the panel, insert the keypad ribbon through the rectangular slot in the control panel. Align label assembly into position by matching the clear viewing window on the label to the rectangular cutout in the panel and gently press into place.
6. Reverse the above procedure.
7. Reestablish electrical power to the dryer.

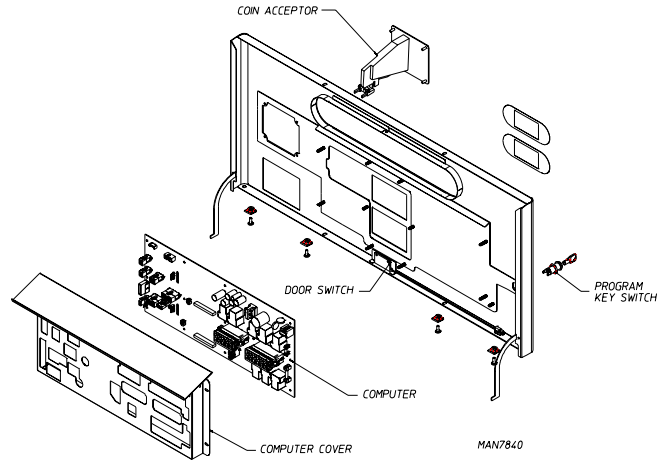

To Replace Microprocessor Exhaust Temperature Sensor Probe

1. Discontinue electrical power to the dryer.
2. Follow procedure for “removing control door and lint door/toe panel.”
3. Loosen the 5/16 Pal nut securing sensor bracket assembly to the dryer.
4. Disconnect sensor bracket harness connector.
5. Install new sensor probe assembly by reversing procedure.
6. Reestablish electrical power to the dryer.

NOTE: If, when power is reestablished, the computer display reads exhaust probe fault check for a loose connection in the wiring.

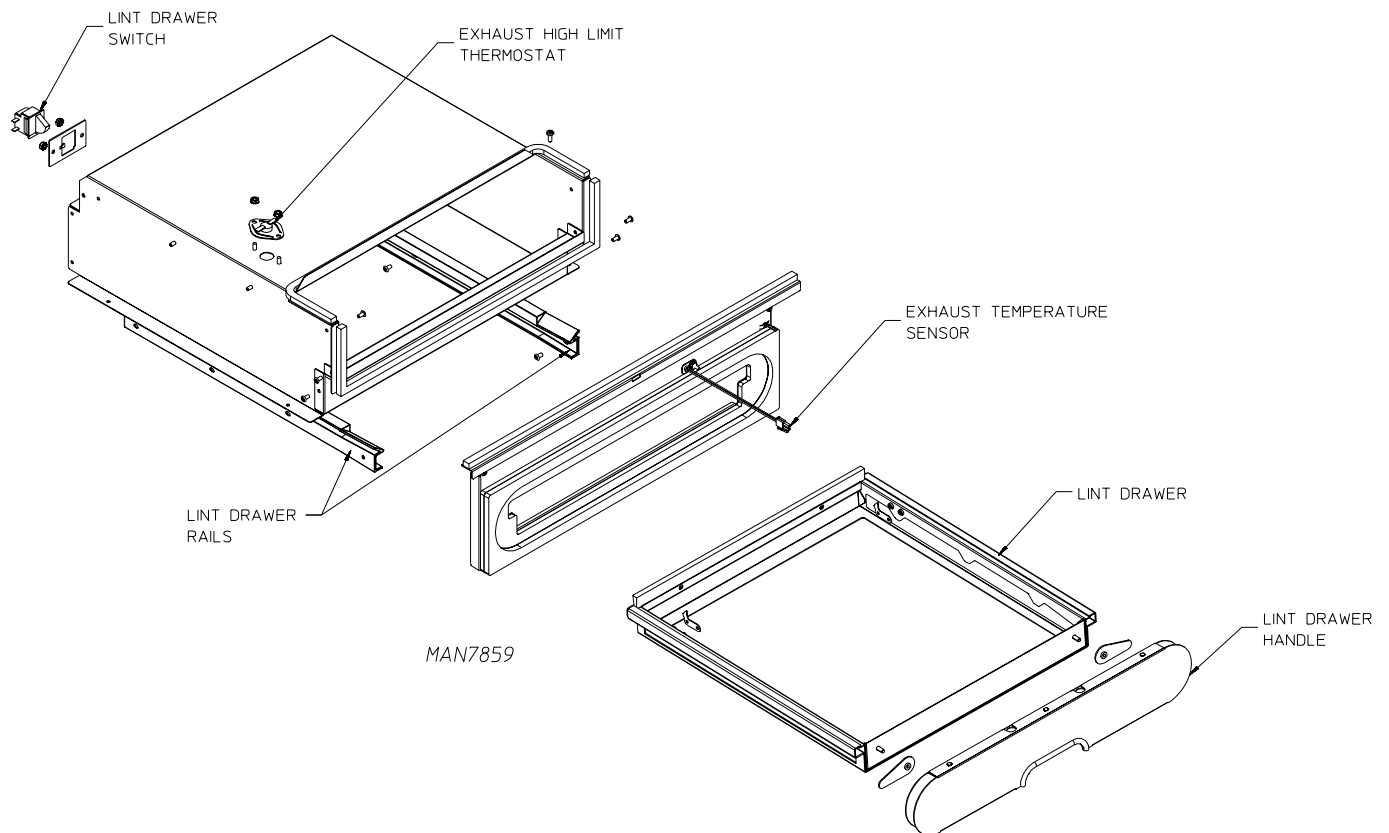

B. GLO-BAR CONTROLS

Removing Burner Tube Assembly

1. Disconnect the electrical power.
2. Follow procedure for "Removing Control Door and Lint Door/Toe Panel."
3. Close shutoff valve in the burners gas supply line.
4. Remove coin chute if dryer is so equipped. (Skip this step when converting bottom pocket.)
5. Disconnect both 3-pin burner electrical plugs.
6. Disconnect (2) union elbows.
7. Remove (6) 1/4-20 nuts.
8. Remove gas valve bracket from dryer.
9. Slide **BOTTOM** valve/burner housing assembly out of dryer.
10. Slide **TOP** valve/burner housing assembly out of dryer.
11. Reverse procedure for reinstallation

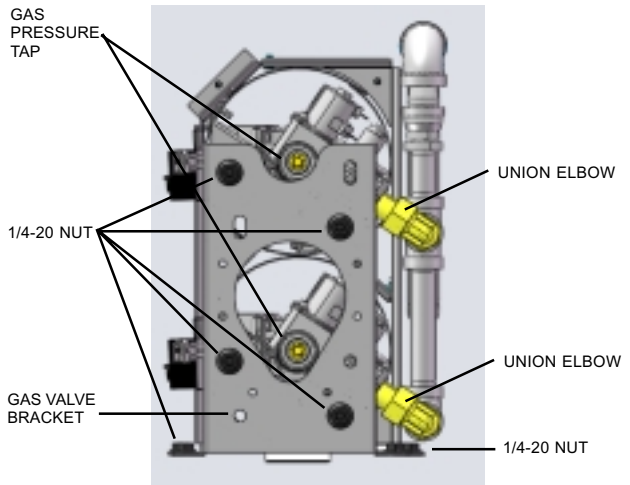

To Replace Globar

1. Discontinue electrical power to the dryer.
2. Follow procedure for "Removing Burner Tube Assembly".
3. Disconnect Glo-Bar connector.
4. Disassemble ignitor from burner by removing the single ignitor mounting screw.
5. Reverse procedure for installing new Glo-Bar ignitor.

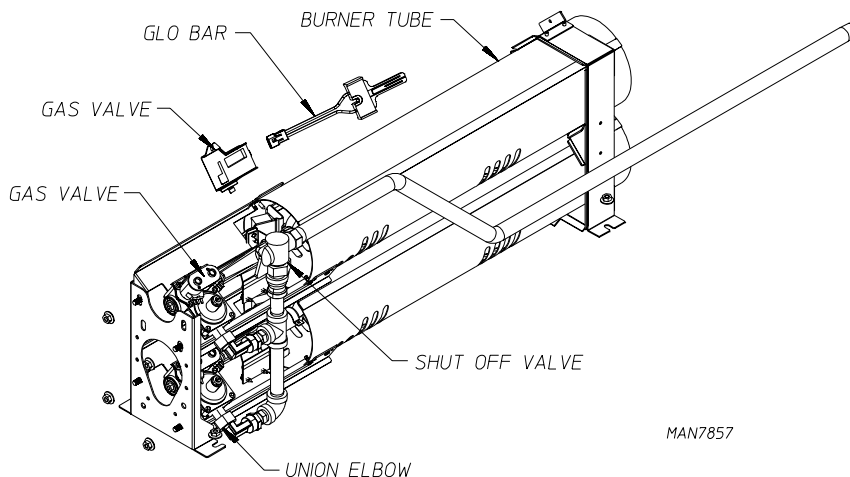

To Replace Gas Valve

1. Discontinue electrical power to the dryer.
2. Follow procedure for "Removing Burner Tube assembly."
3. Disconnect gas valve wiring.
4. Remove valve mounting bracket, manifold, and piping from gas valve.
5. Reverse procedure for installing new gas valve.

WARNING: Test all connections for leaks by brushing on a soapy water solution. NEVER TEST FOR LEAKS WITH A FLAME.

To Replace Main Burner Orifices

1. Refer to "Removing Burner Tube Assembly".
2. Unscrew main burner orifices and replace.

NOTE: Use extreme care when removing and replacing orifices. These orifices are made of brass and are easily damaged.

3. Reverse the removal procedure for reinstallation.

NOTE: Test all connections for leaks by brushing on a soapy water solution. NEVER TEST FOR LEAKS WITH A FLAME.

To Test and Adjust Gas (Water Column) Pressure

There are two types of devices commonly used to measure water column pressure. They are spring/mechanical-type gauges and manometers. The spring/mechanical-type gauge is not recommended, because it is easily damaged and not always accurate. A manometer is simply a glass or transparent plastic tube with a scale in inches. When filled with water and pressure applied, the water in the tube rises showing the exact water column pressure.

NOTE: Manometers are available from the factory by ordering ADC P/N 122804.

1. To test gas water column pressure:
 - a. Connect water column test gauge connection to gas valve pressure tap (1/8" N.P.T.). This pressure tap is located on the outlet (manifold) side of the valve.
 - b. Start dryer. With burner on, the correct water column reading in inches would be:
Natural Gas – 3.0 inches (6.9 mb) water column.
L.P. Gas – 10.5 inches (26.1 mb) water column.
2. To adjust water column pressure (natural gas only, L.P. gas must be regulated at source):
 - a. Remove the brass vent cap on the top of the valve.
 - b. Turn the slotted adjustment screw located under the brass vent cap at the top of the valve. Turn clockwise to increase manifold pressure and counterclockwise to decrease.

NOTE: If correct water column pressure cannot be achieved, problem may be due to an undersized gas supply line, a faulty or underrated gas meter, etc.

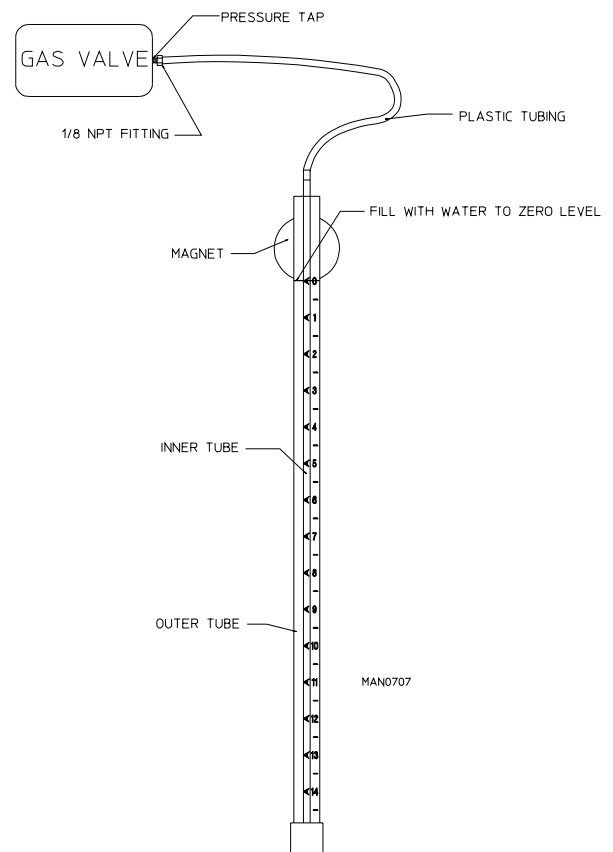

L.P. Gas Conversion Instructions

Disconnect electrical power to the dryer.

IMPORTANT: The following procedures must be performed on both top and bottom tumblers.

Open the panels located just below each loading door.

Close all shutoff valves (for both top and bottom tumbler) in dryer's gas supply line.

Follow procedure for "Removing Burner Tube Assembly."

Using a 3/8" wrench or socket, remove the existing orifice and replace it with an orifice from the kit.

IMPORTANT: Use extreme care when removing and replacing orifice (injector). This orifice (injector) is made of brass, which is easily damaged.

Use a flat screwdriver to remove the regulator vent cap.

- **For unregulated L.P. gas (most countries):** install blocking pin (ADC P/N 140414).

Reinstall the burner tube into the burner tube receiver bracket.

Connect the union and electrical plug.

Repeat these steps for the other burner.

Affix L.P. Conversion Label (ADC P/N 114515) to the dryer's data label.

Complete L.P. Kit Conversion Confirmation Label (ADC P/N 114083) and affix this label as close as possible to the dryer's existing dryer rating (data) label/plate.

Regulate (govern) gas externally (refer to "To Test and Adjust Gas Pressure" in chart on page 17) to the correct gas pressure for the gas being used. Operate dryer through one complete cycle to ensure proper operation.

Affix L.P. Conversion Rating Label Addendum (ADC P/N 114090) as close as possible to the dryer's existing dryer rating (data) label/plate.

IMPORTANT: Never test for leaks with an open flame!!! Use a soapy water solution or product intended for that purpose.

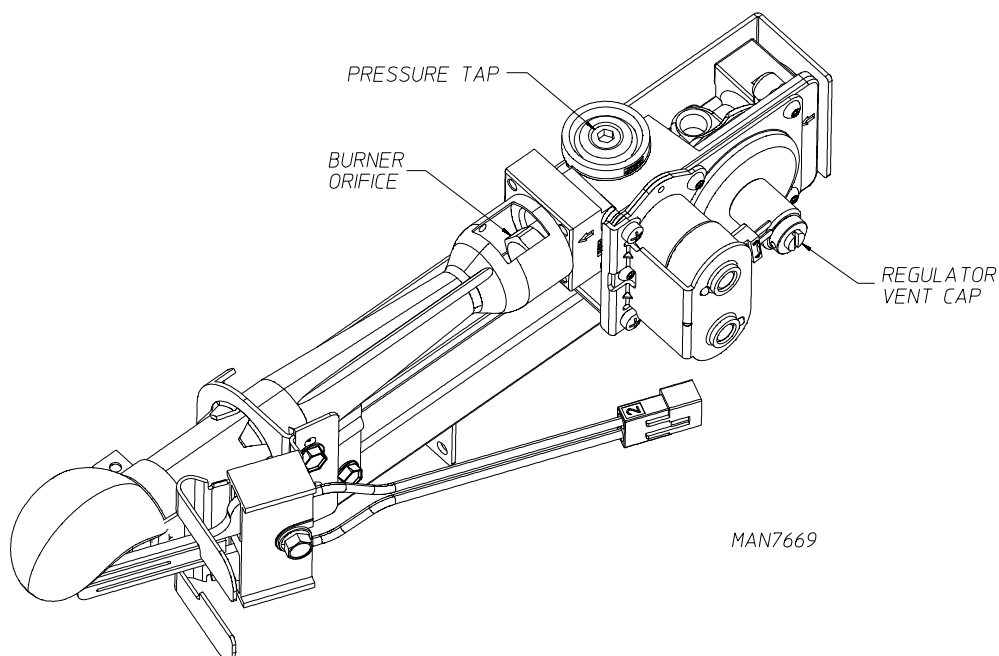

C. THERMOSTATS

To Replace Burner Hi-Limit Thermostat

This thermostat is an important safety device serving as an added protection against failure of the airflow (sail switch) to open in the event of motor failure or reduced airflow condition.

IMPORTANT: Under no circumstances should heat circuit safety devices ever be disabled.

1. Discontinue electrical power to the dryer.
2. Remove back guard.
3. Disconnect wires from hi-limit thermostat.
4. Remove screws securing thermostat to the heat duct. Remove thermostat.
5. Reverse procedure for installing new thermostat.
6. Reestablish electrical power to the dryer.

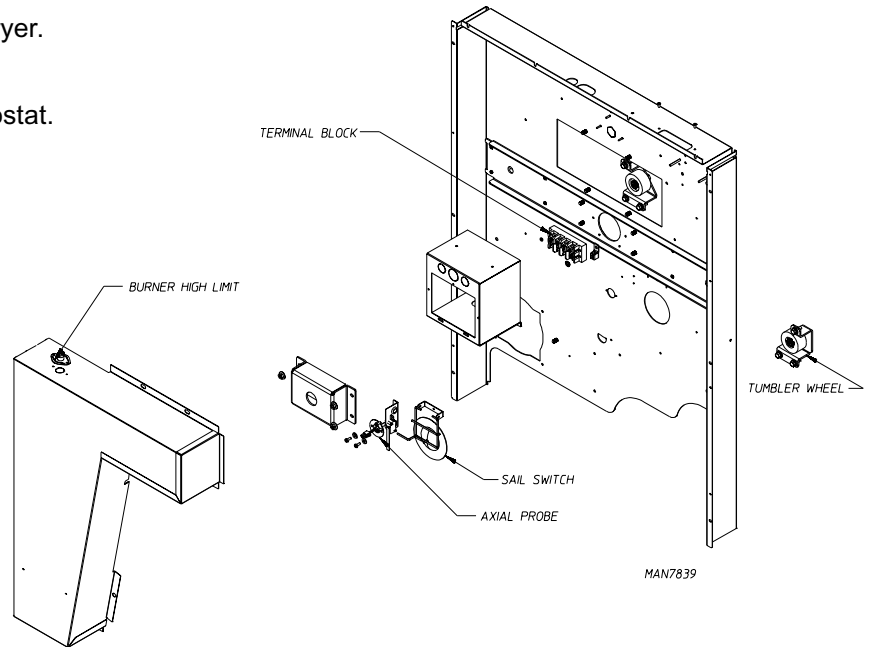

To Replace Lint Compartment / Exhaust Hi-Limit (190° F [87° C]) Thermostat

This thermostat is part of the "lint box assembly" and is secured to the top lint box beneath tumbler. As a safety device, this thermostat will open (shut off) the heating unit circuit if an excessive temperature occurs. The dryer motors will remain on, even if the thermostat is open.

IMPORTANT: Under no circumstances should heat safety devices be disabled.

1. Discontinue electrical power to the dryer.
2. Remove control or lint panel.
3. Locate exhaust hi-limit at front left side of lint box. Remove wires from thermostat and remove the two 11/32" Hex nuts.
4. Reverse this procedure for installing a hi-limit thermostat.
5. Reestablish electrical power to the dryer.

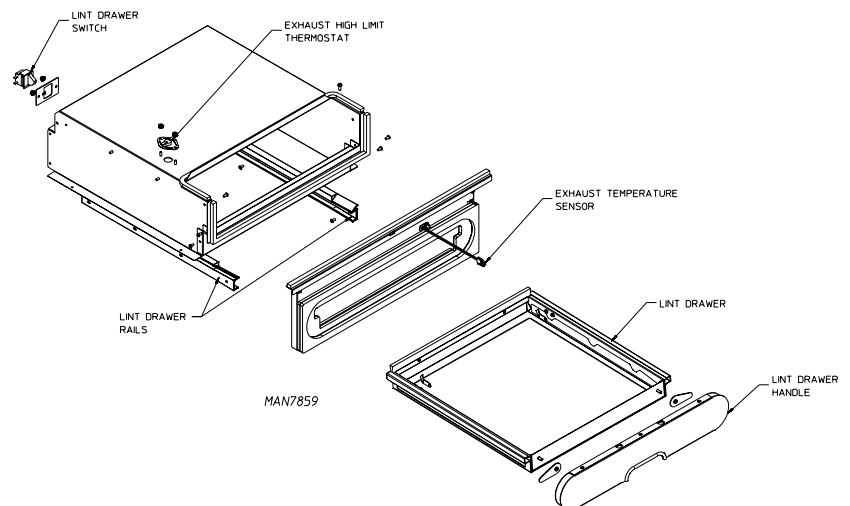

D. SAIL SWITCH ASSEMBLY

To Replace Sail Switch

1. Discontinue electrical power to the dryer.
2. Remove back guard.
3. Disconnect the two wires from the switch.
4. Disassemble sail switch from mounting bracket by removing the two screws securing switch in place.
5. Reverse this procedure for installing new sail switch. Adjust sail switch as described in the next section.

To Adjust Sail Switch

With the dryer operating at a high temperature setting, pull the sail switch away from the burner. The sail switch should open and extinguish the burner. Let the sail switch damper return to the burner wall. The sail switch should close to restart the burner ignition cycle. If the sail switch circuit does not operate as described, bend the actuator arm of the sail switch accordingly until proper operation is achieved.

E. FRONT PANEL AND MAIN DOOR ASSEMBLIES

To Replace Main Door Switch

1. Discontinue electrical power to the dryer.
2. Open main door.
3. Remove the Phillips head screws holding the top or main control panel.
4. Disconnect wiring connecting switch to computer board/harness.
5. Disassemble door switch from bracket by removing two Phillips screws securing the switch to the panel.
6. Reverse this procedure for installing new door switch.
7. Reestablish electrical power to the dryer.

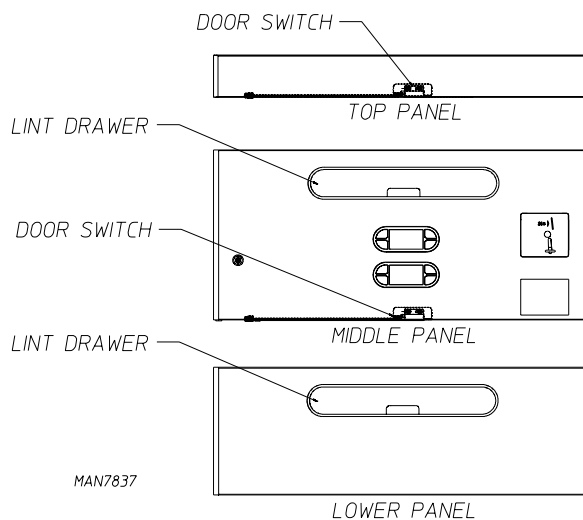

IMPORTANT: Under no circumstances should the door switch be disabled.

To Install New Main Door Glass

1. Remove main door assembly from dryer.
2. Lay main door on flat surface with the rear of the door facing up.
3. Drill all outer perimeter pop rivets and remove door handle.
4. Remove glass and clean all old sealant off main door. This area must be completely cleaned for correct bonding.
5. Apply a narrow bead of silicone (ADC P/N 170730) all around main door area where glass will rest.
6. Install glass onto door adhesive and slightly press glass in place.

IMPORTANT: Do not press hard or silicone thickness between the glass and door, the bead of silicone will be reduced, resulting in poor bonding.

7. The door assembly should now be put in an area where it will not be disturbed for at least 24 hours. Depending on the conditions, the curing time of this adhesive is 24 to 36 hours.
8. Pop rivet the inner door to the outer door and reattach the door handle.
9. After 24-hour curing period, install main door on dryer by reversing Step #1-2.

To Replace Front Panel

1. Discontinue electrical power to the dryer.
2. Follow procedure for removal of “control door and lint door/toe panel.”
3. Remove main door assembly.
4. Open control (service) door and follow procedure for removal of computer panel if replacing bottom panel.
5. Remove two TORX® T-20 screws above lint drawer to left and right side.
6. Remove the two TORX® T-20 screws securing front panel to the dryer one top left and one top right of side panel.
7. Loosen belt to allow for easier removal of panel.
8. Remove wires running up through front panel.
9. Pull top of panel out until roughly a 35 degree angle and then lift to remove.
10. Reverse this procedure for installing new front panel.
11. Tighten belt to original specifications.
12. Reestablish electrical power to the dryer.

To Replace Tumbler

1. Discontinue electrical power to the dryer.
2. Remove tumbler belt from motor.
3. Follow procedure for removal of front panel assembly.
4. Remove the four screws at the backside of the tumbler holding the dome shaped plate.
5. Remove tumbler assembly from front of dryer.
6. Reassemble components onto dryer by reversing steps 2 through 5.
7. Reestablish electrical power to the dryer.

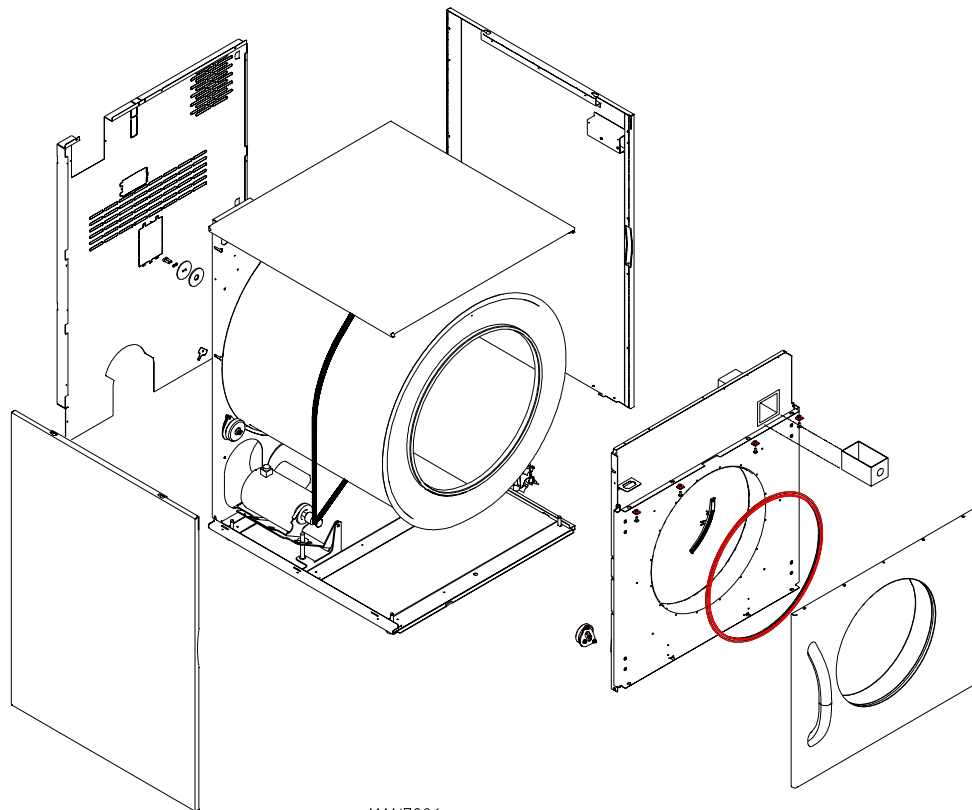

MAN7806

To Replace Drive Belt

1. Follow procedure to remove computer panel and lower toe panel.
2. Loosen tension of belt so that it can be easily rolled off the motor pulley.
3. Follow procedure "To Replace Front Panel" to allow removal and installation of new belt.
4. Slide new belt over the tumbler motor sheave.
5. Reassemble components putting belt around motor pulley after front support panel is re-assembled.
6. Reestablish electrical power to the dryer.

To Replace Drive Motor

1. Discontinue electrical power to the dryer.
2. Remove drive belt.
3. Disconnect wiring harness from motor. For top pocket motor it will be necessary to remove the top of the bottom pocket exhaust section. This is held in by two nuts and six TORX® screws (refer to drawing below).
4. Remove nuts holding motor mount to base of machine then remove motor bracket assembly.
5. Remove motor from bracket then replace with new motor.
6. Reinstall motor bracket assembly to dryer.
7. Replace belt back around motor pulley.
8. Reestablish electrical power to the dryer.

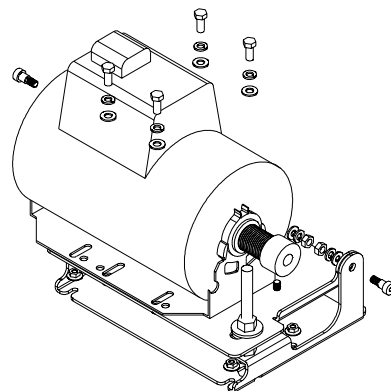
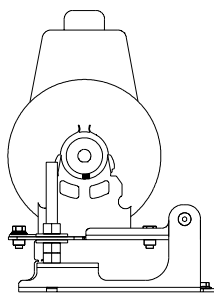

MAN7805

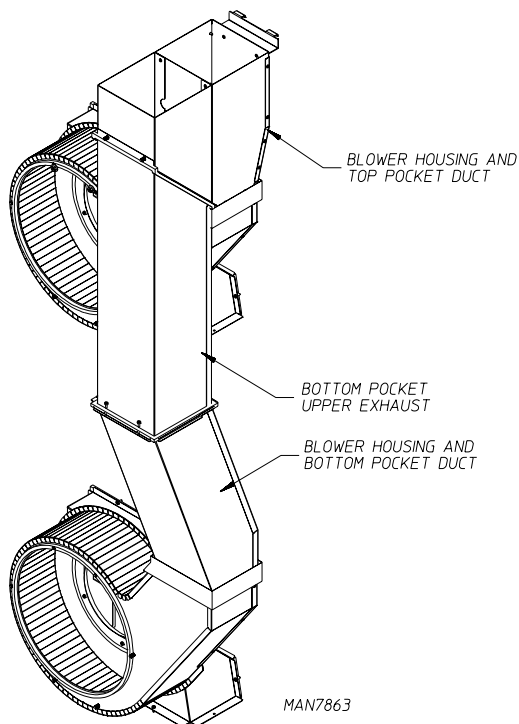

MAN7863

Removing Blower Motor

For ES50/50 (rear exhaust)

1. Discontinue electrical power to the dryer.
2. Remove back guard.
3. Disconnect the harness from motor and capacitor.
4. To remove blower motor unscrew the top cover of the blower housing.
5. The blower motor can now be unbolted from the cover of the blower housing.
6. Reverse procedure for installation.

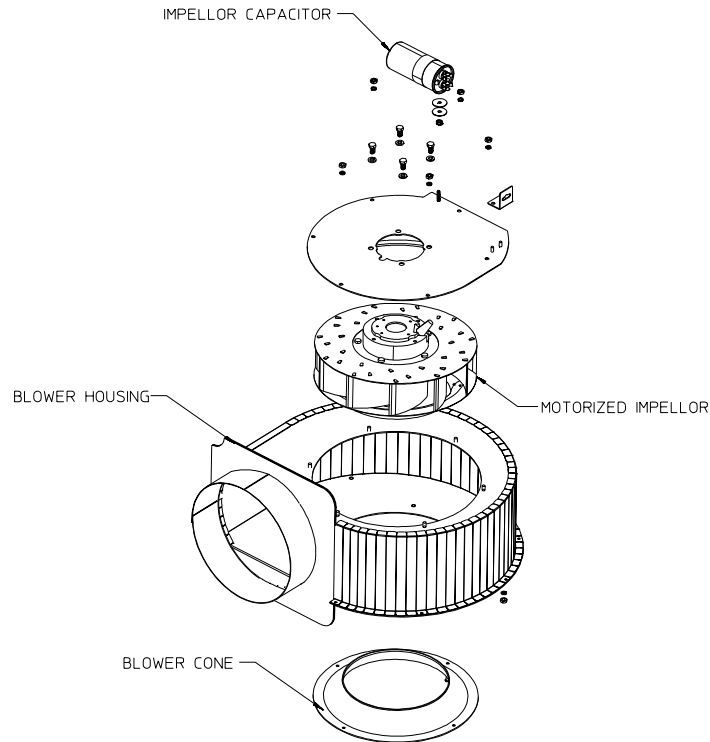

MAN7858

For ES50/50TE (top exhaust)

1. Discontinue electrical power to the dryer.
2. Remove back guard.
3. Disconnect the harness from blower motor.
4. Disconnect and remove relay panel assembly.
5. Remove four nuts holding blower motor mount to blower housing.
6. Pull out blower motor mount.
7. Remove nuts holding fan to motor and remove fan.
8. Unbolt motor from mount and remove.
9. Reverse procedure for installation.

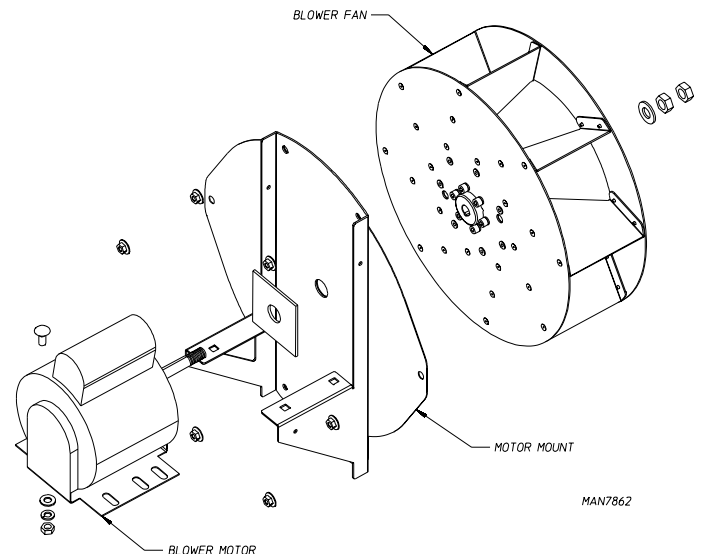

MAN7862

F. TO REPLACE LINT DRAWER SWITCH

1. Discontinue electrical power to the dryer.
2. Remove the two nuts holding the lint switch bracket in place.
3. Remove lint switch cover and disconnect the two terminals of the switch.
4. Remove switch by pressing tabs together and push switch out.
5. Install new switch by reversing procedure.

3: Diagnostic Mode

1: FAULT RECORDING

*1: UPPER DRYER FAULTS**

When a fault is recorded on the top pocket, it can be viewed in this location. If no fault(s) have been recorded, then "NO UPPER FAULTS" will be displayed.

1: *(Description of fault)*

2: *(Description of fault)*

3: *(Description of fault)*

4: *(Description of fault)*

5: *(Description of fault)*

*2: LOWER DRYER FAULTS**

When a fault is recorded on the bottom pocket, it can be viewed in this location. If no fault(s) has been recorded, then "NO LOWER FAULTS" will be displayed.

1: *(Description of fault)*

2: *(Description of fault)*

3: *(Description of fault)*

4: *(Description of fault)*

5: *(Description of fault)*

* Single units will only have one set of faults.

3: EVENTS

E1:XX

E2:XX

E3:XX

E4:XX

E5:XX

E6:XX

E7:XX

E8:XX

E9:XX

EA:XX

EB:XX

EC:XX

ED:XX

RESET

This will reset all of the event counts to 0.

All CODES starting with an "E" represent an event. An event failure is one that would still allow the dryer to run in a safe condition. The number after the "E" code indicates the amount of times that event failure occurred. The 13 Event Code failures are listed in the following table.

| EVENT I.D. | FAILURE DESCRIPTION |
|------------|--------------------------------------------------|
| E1 | Top Radiant Sensor fault count |
| E2 | Top Burner Ignitor fault count |
| E3 | Top Exhaust High Limit |
| E4 | Bottom Radiant sensor fault count |
| E5 | Bottom Burner ignitor fault count |
| E6 | Bot Exhaust High Limit |
| E7 | Coin 1 Bad Coin count |
| E8 | Coin 2 Bad Coin Count |
| E9 | Upper pocket forward rotation sensor fault count |
| EA | Upper pocket reverse rotation sensor fault count |
| EB | Lower pocket forward rotation sensor fault count |
| EC | Lower pocket reverse rotation sensor fault count |
| ED | S.A.F.E. DISABLED – Water not connected |

2: DIAGNOSTIC CYCLE

Diagnostic Mode enables the user to run the dryer(s) and access items to troubleshoot a problem with the dryer. When the diagnostic menu is first selected, the controls will prompt the user to start a cycle as seen below.

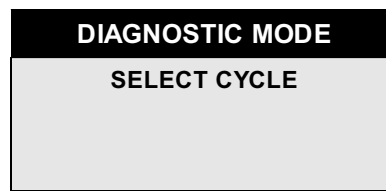

NOTE: Once a cycle is selected, the control will clear the fault condition so that dryer can be started. This will also clear all credit in escrow and any cycle time remaining on both pockets.

When the dryer is still in an idle state, a cycle must be selected. Once a cycle is selected, the unit will enter into Running Mode. The cycle's time and temperature will correspond to the selected cycle's parameter settings under SETUP Mode.

Once a cycle has been selected the keys will now enable the user to access different features.

- Pressing the HI/UP ARROW key will increase the time of the current running cycle. (1 minute at a time.)
- Pressing the LOW/DOWN ARROW key will decrease the time of the current running cycle. (1 minute at a time.)
- Pressing the PAUSE/STOP key will pause the current running cycle.
- Pressing the MED/ENTER key will access the HELP MENU.

NOTE: If the program key switch is toggled while a cycle is running and no diagnostic codes are being reported, the current diagnostic cycle will continue to run in Customer Mode. Once the cycle has finished the control should return to operating in the normal Customer Mode.

When a cycle is running, the control will display DIAGNOSTIC MODE at the top of the display.

If a fault occurs during Diagnostic Mode, the control will enter into a fault cool down and the occurring fault will be displayed. The fault can be cleared by reentering the diagnostic cycle.

3: HELP MENU

The help menu allows the user to view the status of different parts of the dryer. When a feature is highlighted, the center section will list that feature and its current status. The items in the help menu will refer to the current running cycle that was selected in Diagnostic Mode.

Pressing the HI/UP ARROW key will allow the user to move the highlighted bar around the help menu screen. For example, highlighting "S" will show the status of the sail switch.

Pressing the PAUSE/STOP key will return the controls to Diagnostic Mode.

The table below shows the standard features available and the symbol they correlate with.

| FEATURE SYMBOL | FEATURE TEXT | FEATURE | FEATURE INFORMATION |
|----------------|------------------------|------------------------------------------------|----------------------|
| EXH | EXHAUST TEMP PROBE | Exhaust Temperature Probe | (in Deg. F or C) |
| AXL | AXIAL TEMP PROBE | Axial Thermistor Probe | (in Deg. F or C) |
| RPM | TUMBLER ROTATION SPEED | Tumbler Speed in <u>Revolutions Per Minute</u> | R.P.M. |
| MIN | TIME REMAINING | Time remaining in the diag. cycle | 0 to 99 (in minutes) |
| CODE | HELP CODE MENU | Help Menu Code | Help Codes |
| T1 | THERMOSTAT BURNER 1 | Thermostat (Heat Output Burner 1) | ON - OFF |
| T2* | THERMOSTAT BURNER 2 | Thermostat (Heat Output Burner 2) | ON - OFF |
| H1 | HEAT RETURN BURNER 1 | Heat Return Burner 1 | ON - OFF |
| H2* | HEAT RETURN BURNER 2 | Heat Return Burner 2 | ON - OFF |
| C1 | HEAT RELAY 1 CONTACTS | Heat relay 1 contacts | OPEN - CLOSED |
| C2* | HEAT RELAY 2 CONTACTS | Heat relay 2 contacts | OPEN - CLOSED |
| B | BLOWER | Fan output | ON - OFF |
| F | FORWARD | Forward drive output | ON - OFF |
| R | REVERSE | Shows reversing relay is on | ON - OFF |
| D | DOOR | Main Door | OPEN - CLOSED |
| L | LINT | Lint Door | OPEN - CLOSED |
| P | WATER PRESSURE | H ₂ O Input | ON - OFF |
| S | SAIL SWITCH | Sail Switch | OPEN - CLOSED |
| V | VAULT SWITCH | Vault Switch | OPEN - CLOSED |
| W | WATER OUTPUT | S.A.F.E. output | ON - OFF |

If the help menu feature “CODE” is selected, the center section will present “Help Codes” and “Events”. All of the items in the code menu will automatically scroll up and continue to scroll until LOW/DOWN ARROW key is pressed to select a new help menu feature.

All CODES starting with an “H” represent some condition that could interfere with the proper functioning of the dryer. There could be up to 3 “H” codes listed within the HELP MENU.

- H1 represents the last failure recorded.
- H2 represents the second to last failure recorded.
- H3 represents the third to last failure recorded.

Each Help Code will be followed by a two digit code. This two digit code will reflect a particular issue.

| HELP CODE | CODE DESCRIPTION |
|------------------|--------------------------------------------------|
| 81 | Lower Exhaust Probe Fault |
| 86 | Upper Exhaust Probe Fault |
| 87 | Upper Axial Probe Fault |
| 82 | Lower Axial Probe Fault |
| 89 | Upper Sail Switch Open Fault |
| 88 | Upper Sail Switch Closed Fault |
| 84 | Lower Sail Switch Open Fault |
| 83 | Lower Sail Switch Closed Fault |
| 90 | Upper Rotation Sensor Fault |
| 91 | Lower Rotation Sensor Fault |
| 92 | Gen 2 Card Reader Communication Fault |
| E1 | Top Radiant Sensor fault count |
| E2 | Top Burner Ignitor fault count |
| E3 | Top Exhaust High Limit |
| E4 | Bottom Radiant sensor fault count |
| E5 | Bottom Burner Ignitor fault count |
| E6 | Bottom Exhaust High Limit |
| E7 | Coin 1 Bad Coin count |
| E8 | Coin 2 Bad Coin Count |
| E9 | Upper pocket forward rotation sensor fault count |
| EA | Upper pocket reverse rotation sensor fault count |
| EB | Lower pocket forward rotation sensor fault count |
| EC | Lower pocket reverse rotation sensor fault count |
| ED | S.A.F.E. DISABLED – Water not connected |

FAULTS

EXHAUST PROBE

An exhaust probe fault occurs when the control detects that the exhaust temperature transducer is reading a temperature that is out of the probe's normal operating temperature range for more than 3-seconds. There is an automatic fault clearing feature for this fault. If the fault condition no longer exists, the control will clear the fault condition and return to READY Mode.

AXIAL PROBE

An axial thermistor probe fault occurs when the control detects that the axial thermistor is reading a temperature that is out of the probe's normal operating temperature range for more than 30-seconds, usually an open or shorted probe condition. There is an automatic fault clearing feature for this fault. If the fault condition no longer exists, the control will clear the fault condition and return to READY Mode.

SAIL SWITCH CLOSED

A sail switch closed fault occurs when a cycle is starting up from either READY Mode, PAUSE Mode or any other idle state. Once a temperature/cycle is selected the control will start the time and verify the sail switch is open, if it is not, the control will display on the screen that the control is "STARTING" and will not turn on the FAN, DRIVE or HEAT. The control will allow the sail switch 10-seconds to open before the control faults out with a SAIL SWITCH CLOSED FAULT. Once a SAIL SWITCH CLOSED FAULT is detected the control will log the fault and will not allow the cycle to continue. The control will display "SAIL SWITCH CLOSED FAULT, SELECT CYCLE TO RESTART, when the fault is detected.

SAIL SWITCH OPEN

A sail switch open fault occurs when a cycle is starting from either READY Mode, PAUSE Mode or any other idle state. If the sail switch does not close within the allotted 10-seconds the control will log the fault and will not allow the cycle to continue. The control will display "SAIL SWITCH OPEN FAULT, CHECK MAIN DOOR AND LINT ACCESS AND SELECT CYCLE TO RESTART". A sail switch open fault can also occur once a cycle is in process. If the control detects that the sail switch has opened, the heat will immediately turn off and if the sail switch fails to close within the allotted 30-seconds, the control will fault and display "SAIL SWITCH OPEN FAULT, CHECK MAIN DOOR AND LINT ACCESS AND SELECT CYCLE TO RESTART".

ROTATION SENSOR FAULT

A rotation sensor fault occurs when the control is in a cycle and does not detect any rotation sensor pulses in more than 10-seconds.

EXHAUST HIGH TEMP FAULT

An exhaust high temperature fault occurs when the exhaust probe is detecting a tumbler temperature that is 20° F above the maximum dryer temperature set point for more than 10-seconds.

BLOCKED COIN DROP

This fault occurs if the control senses a blockage in the coin input. If the coin input is blocked for more than 8-seconds the control will go to out of order and will not allow the control to start a cycle. This fault has both automatic and manual fault clearing. If the condition is corrected the control will recover from out of order immediately after the blockage is no longer seen.

EVENTS

RADIANT SENSOR FAULT COUNT

A radiant sensor fault count will occur when a gas model dryer attempts to turn on the burner system and never receives a 120V return signal within a predefined time.

BURNER IGNITER FAULT COUNT

A burner ignition fault count will occur when a gas model dryer attempts to turn on the burner system and receives a 120V on the burner return signal but it does not transition to a 0V return signal within a predefined time.

EXHAUST HIGH LIMIT

This location is a count of the times that the exhaust high limit has been sensed in the open position.

BAD COIN COUNT

This location is a count of all the bad coin occurrences that were detected from the coin input.

FORWARD ROTATION SENSOR FAULT

A forward rotation fault pertains only to reversing machines. The way this fault works is if the dryer is reversing and is running a cycle that has the reversing option enabled, if a rotation sensor fault condition is detected, the drive output would be shut off. Then the dryer will transition to a reversing drive output. If the dryer continues to run without an issue, the machine will continue to run with the forward drive output disabled until the next cycle is started. If the Reversing Mode also fails the control will enter a ROTATION SENSOR FAULT disabling the machine. The next cycle should operate with both drive outputs, that way, if the issue still exists the control will fault out again disabling the fault drive output.

REVERSE ROTATION SENSOR FAULT

REVERSE ROTATION SENSOR FAULT is identical to FORWARD ROTATION FAULT, however it pertains to the reversing drive output instead of the forward drive output.

S.A.F.E. DISABLED – WATER NOT CONNECTED

This event pertains only to machines with a fire detection system. If the control senses a lack of water pressure, this event will appear.

SECTION VI

TECHNICAL INFORMATION

A. DATA LABEL

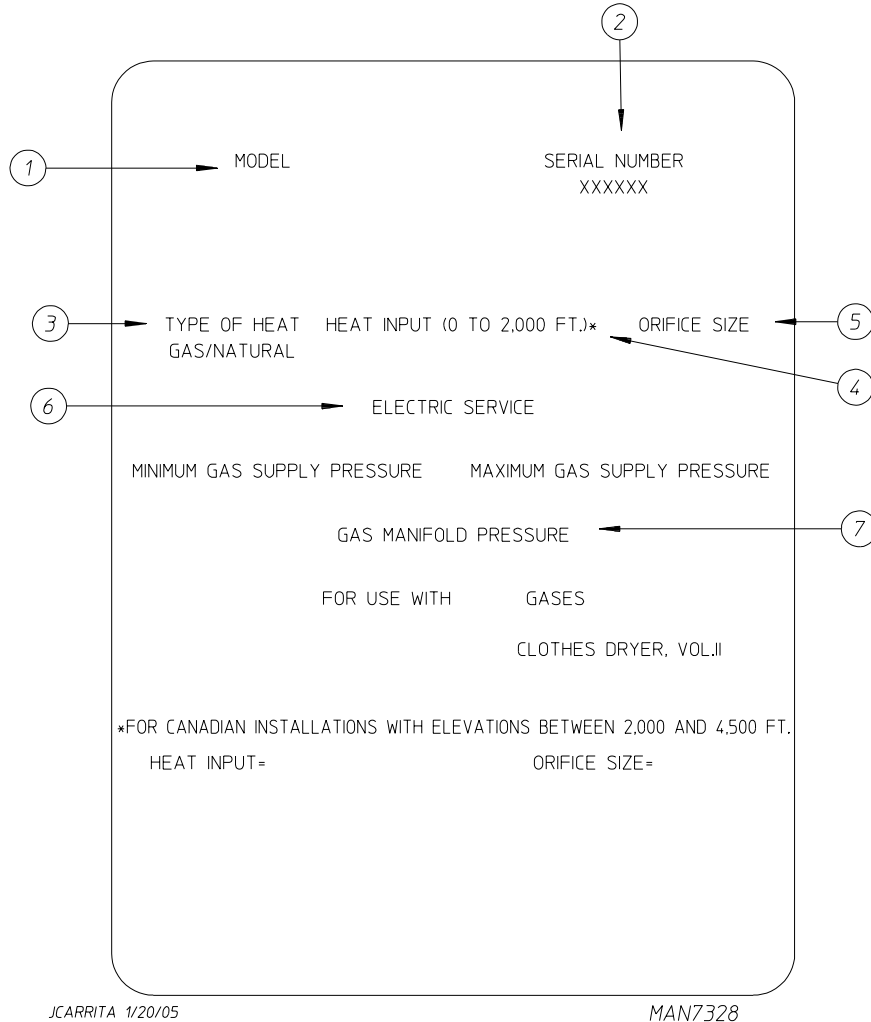

When contacting ADC, certain information is required to ensure proper service/parts information. This information is on the data label, located on the top left hand corner of the dryer, viewed from the rear (refer to the illustration above). When contacting ADC, please have the model number and serial number readily accessible.

1. **MODEL NUMBER** – This describes the style of dryer and type of heat (gas, electric, or steam).
2. **SERIAL NUMBER** – Allows the manufacturer to gather information on your particular dryer.
3. **TYPE OF HEAT** – This describes the type of heat for your particular dryer, gas (either natural gas or L.P. gas), electric, or steam.
4. **HEAT INPUT** (For Gas Dryers) – This describes the heat input in British thermal units per hour (Btu/hr) or kilowatts (kW).
5. **ORIFICE SIZE** (For Gas Dryers) – Gives the number drill size used.
6. **ELECTRIC SERVICE** – This describes the voltage and current rating for a particular model.
7. **GAS MANIFOLD PRESSURE** (For Gas Dryers) – This describes the manifold pressure taken at the gas valve tap.

B. USING A MANOMETER

How To Use A Manometer

1. With dryer in nonoperating mode, remove plug on the gas valve pressure tap.
2. Attach plastic tubing to pressure tap. Fitting is supplied with manometer (refer to the illustration).
3. Attach manometer to the dryer using magnet.

NOTE: Place manometer in a position so that readings can be taken at eye level.

4. Fill manometer with water, as shown in the illustration, to the zero level.
5. Start dryer. With burner on, take a reading.
 - a. Read water level at the inner tube. Readings should be taken at eye level.
 - b. Correct readings should be:
 - Natural Gas: 3.0 inches (6.9 mb) water column.
 - L.P. Gas: 10.5 inches (26.1 mb) water column.
6. If water column pressure is incorrect refer to "TO ADJUST GAS PRESSURE."
7. Reverse procedure for removing manometer.

